

**EAN CODE :**  
3276007191790  
3276007191981

2025/01-V01

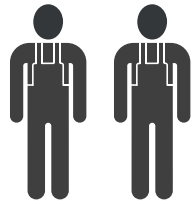

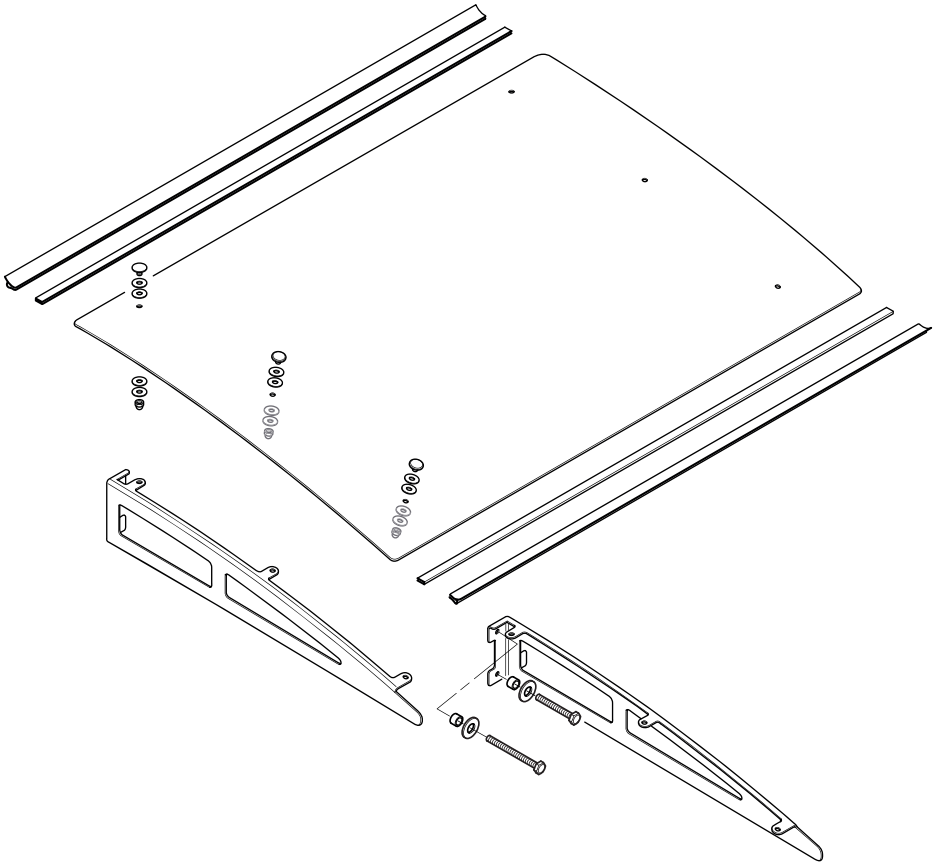

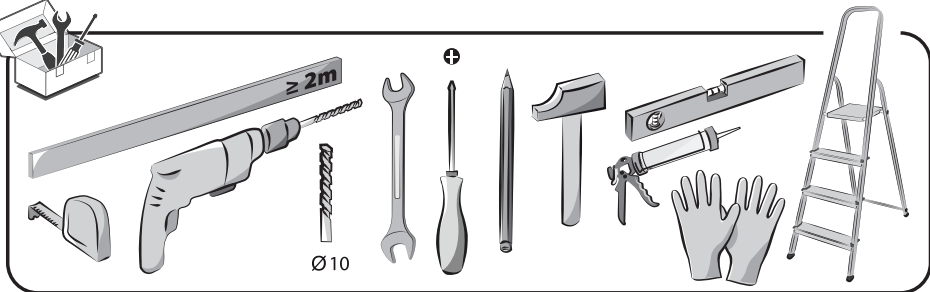
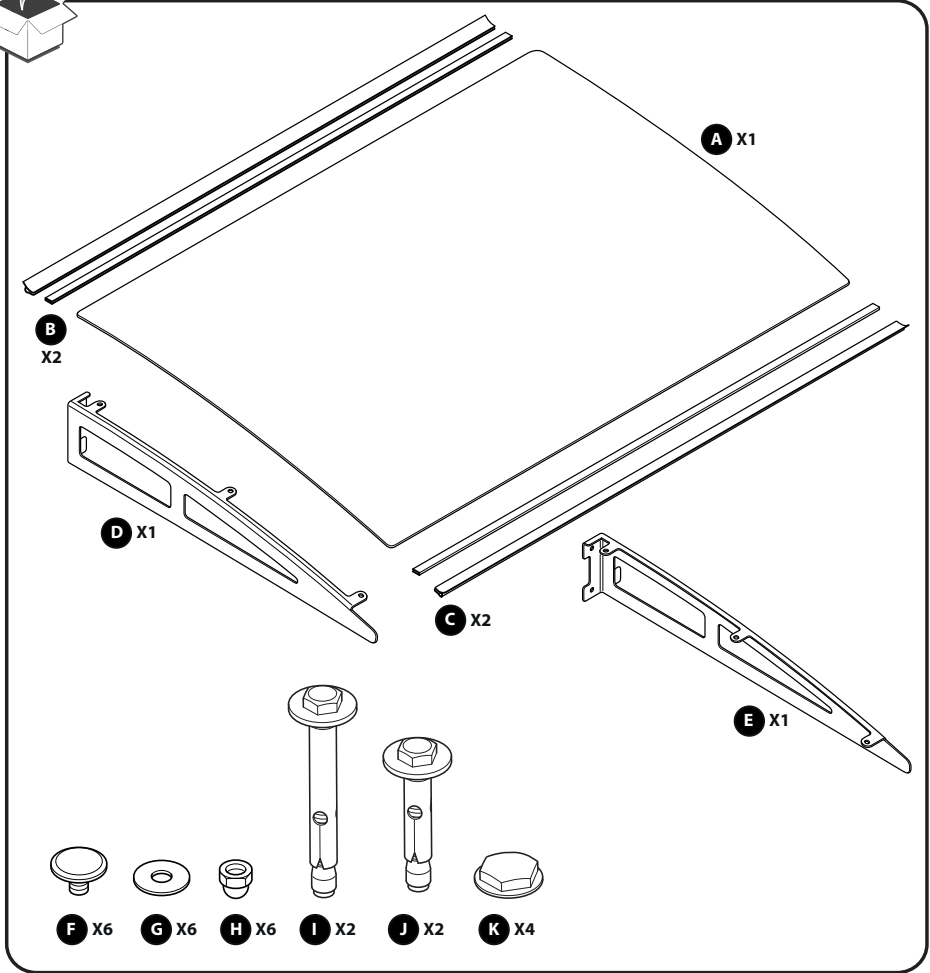



SL: Montaža / EN: Assembly

5 → 8



SL: Varnostna navodila / EN: Safety instructions

9 → 18

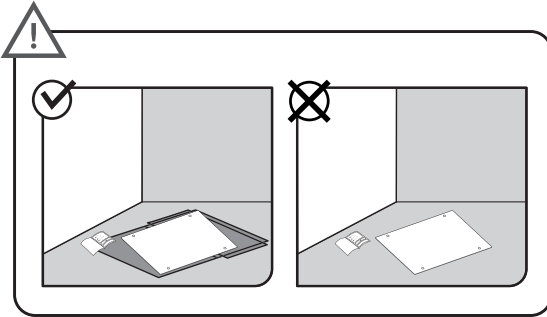

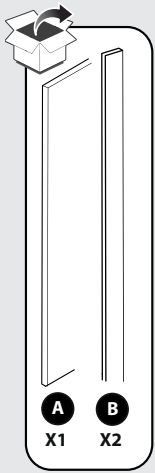

1

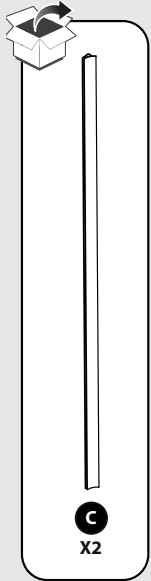
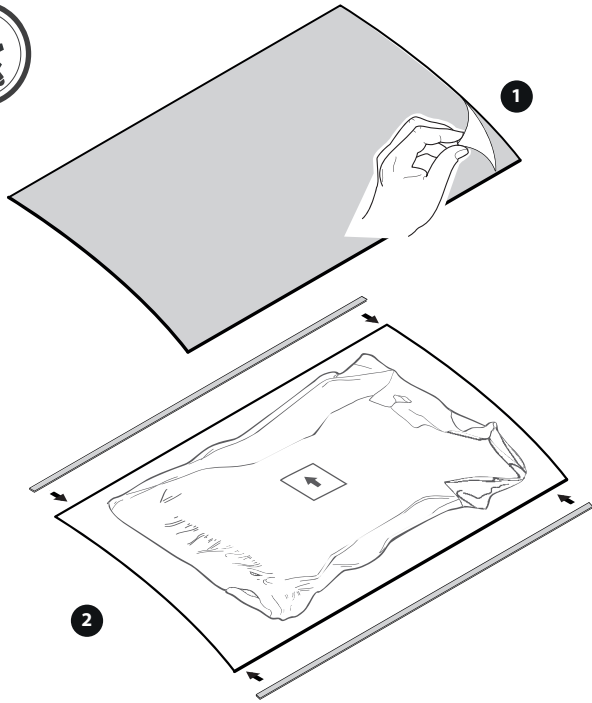

2

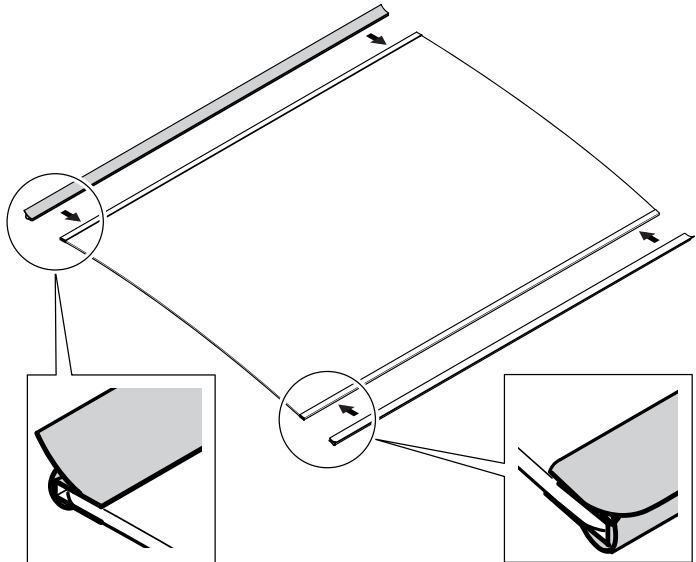

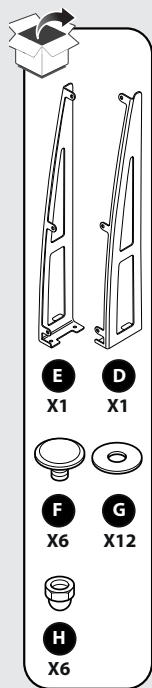

**3**

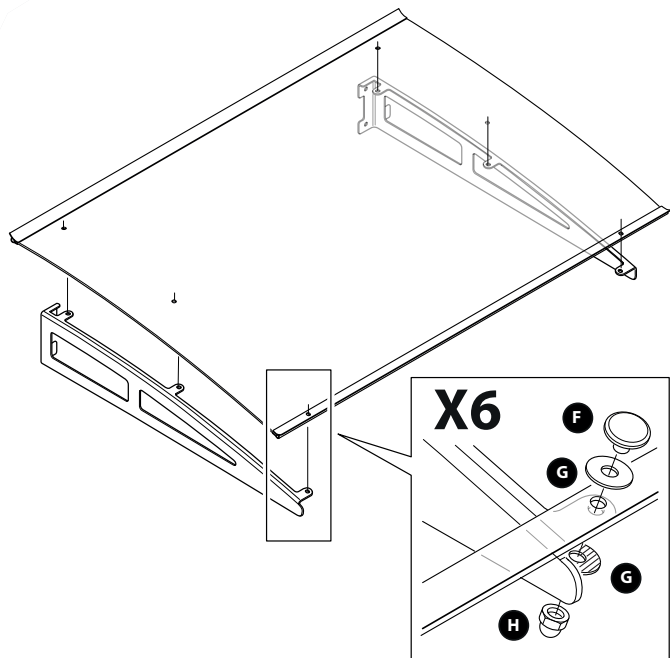

**4**

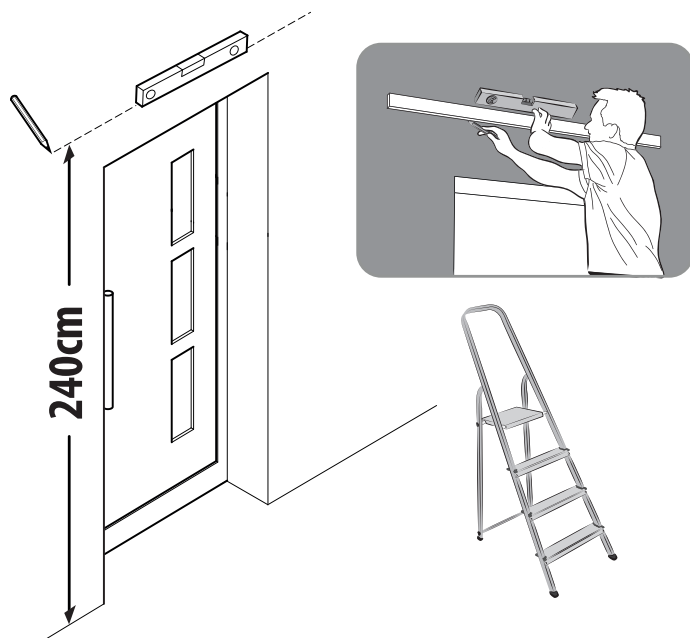

5

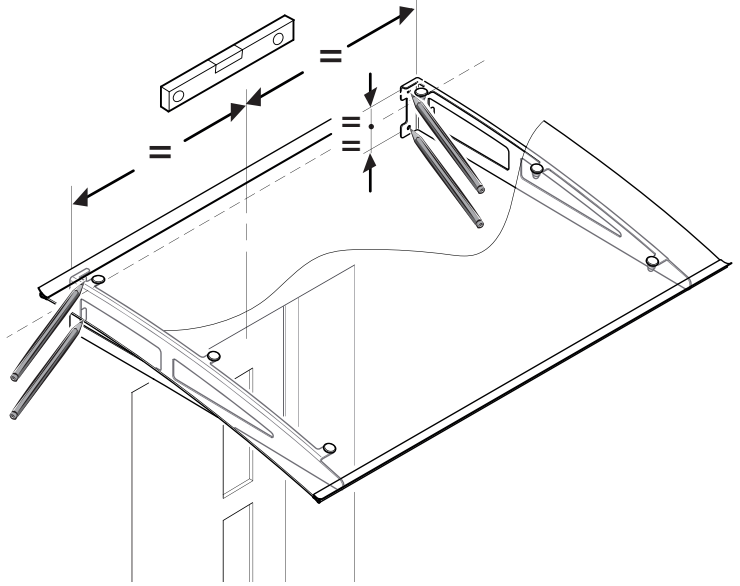

6

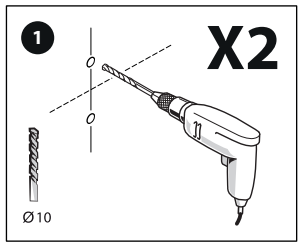
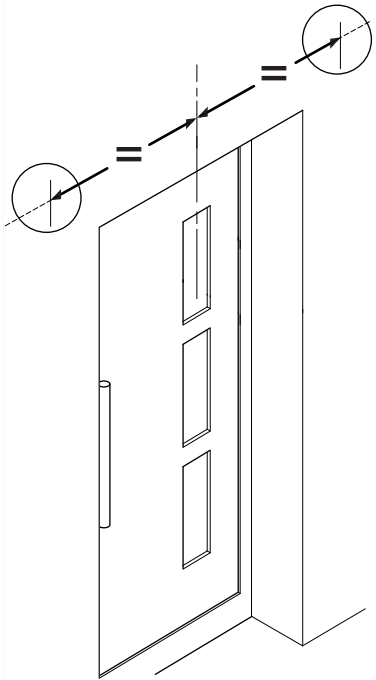

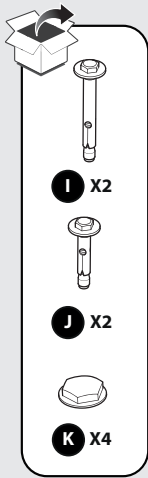

7

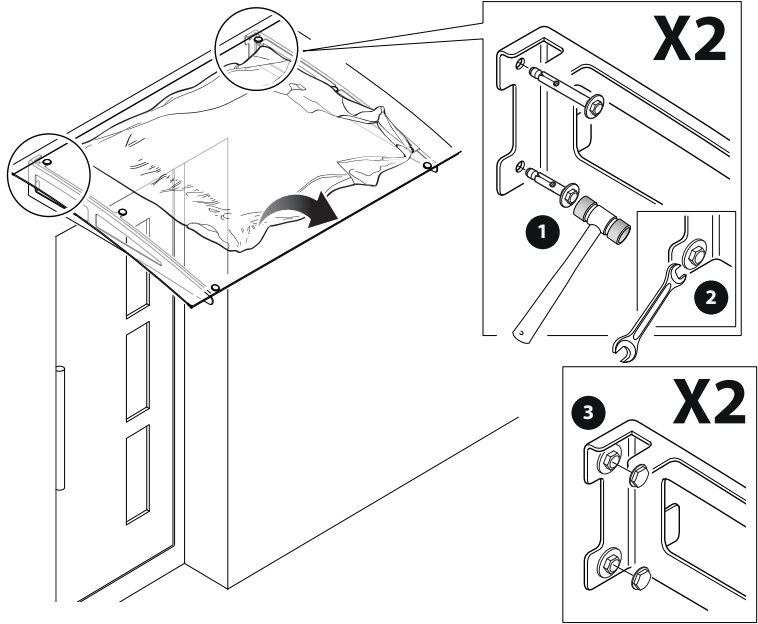

8

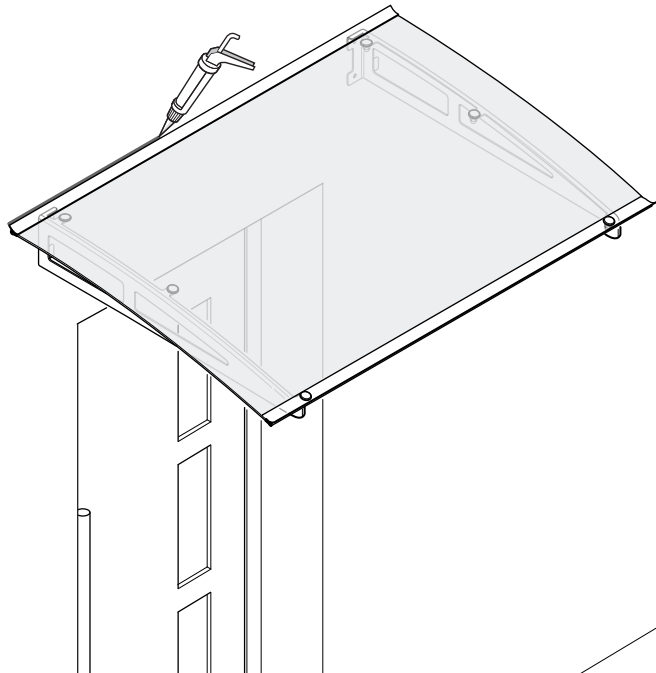





## Predstavitev

SL

EN

Zahvaljujemo se vam za izbiro tega izdelka. Pri načrtovanju in izdelavi naših izdelkov si prizadevamo zagotoviti odlično kakovost, ki ustreza potrebam uporabnikov. Z upoštevanjem teh navodil lahko optimizirate življenjsko dobo izdelka.

**POMEMBNO! DA BI BILI Z IZDELKOM MED NAMESTITVIJO, UPORABO IN VZDRŽEVANJEM KAR NAJBOLJ ZADOVOLJNI, VAM PRIPOROČAMO, DA PRED UPORABO IZDELKA NATANČNO PREBERETE TA UPORABNIŠKI PRIROČNIK. UPOŠTEVAJTE OSNOVNA VARNOSTNA OPOZORILA V TEM PRIROČNIKU IN GA SHRANITE ZA PRIHODNJO UPORABO.**



**POMEMBNO, SHRANITE PRIROČNIK ZA POZNEJŠO UPORABO: NATANČNO PREBERITE TA PRIROČNIK.**

### Kazalo

1. Predvidena uporaba nadstreška
2. Varnostna navodila
3. Montaža
4. Skladiščenje
5. Vzdrževanje
6. Garancija

## 1. PREDVIDENA UPORABA NADSTREŠKA

Ta izdelek je običajno nameščen nad vrati ali oknom in se uporablja za zaščito pred sončnimi žarki in vremenskimi vplivi.

Po končanem razpakiranju preverite, ali je izdelek popoln in ali ima vso dodatno opremo (če je potrebna). Če je izdelek poškodovan ali okvarjen, ga ne uporabljajte in ga vrnite prodajalcu.

Če ta izdelek podarite tretji osebi, ji izročite tudi ta navodila za uporabo.

## 2. VARNOSTNA NAVODILA

### 2.1 SPLOŠNA VARNOSTNA OPOZORILA

#### • POZOR:

- Da bi se izognili nevarnosti prevrnitve, mora biti ta kos pohištva/izdelek varno pritrjen na steno. Prepričajte se, da je stena primerna in dovolj trdna, da prenese obremenitev kosa pohištva/izdelka in vzdrži sile, ki nastajajo na pritrtilnih točkah. Zaradi nepravilne pritrditve lahko kos pohištva/izdelek pade in povzroči hude poškodbe. Če ste v dvomih glede namestitve, se posvetujte s prodajalcem ali se obrnite na strokovnjaka.
- Uporabite vijake, podložke in zatiče, ki so primerni za vrsto materiala stene.
- Preverite, ali priloženi pritrtilni elementi ustrezajo vaši namestitvi. Za nasvet o tem, kateri vijaki in pritrtilni elementi so primerni za vašo steno, se obrnite na specializiranega prodajalca.

- Streha nadstreška je podprta z nosilci, pritrjenimi na steno; ti niso namenjeni prenašanju drugih obremenitev. Da bi preprečili poškodbe izdelka ali oseb, na profile ne obešajte ali postavljajte predmetov.

## 2.2 SIMBOLI NA IZDELKU



Pred uporabo izdelka preberite in razumite vsa navodila ter upoštevajte vsa opozorila in varnostna navodila.

## 2.3 SIMBOLI V TEM PRIROČNIKU



Vrsta in vir nevarnosti: Ta simbol pomeni, da lahko neupoštevanje tega opozorila povzroči škodo na enoti, okolju ali drugi lastnini..



Opomba: Ta simbol označuje pomembne informacije za boljše razumevanje izdelka.



Preberite priročnik: Ta simbol označuje, da morate natančno prebrati uporabniški priročnik.



Ta izdelek je mogoče reciklirati. Če ni več uporaben, ga oddajte v centru za recikliranje odpadkov..

## 2.4 VARNOST NA DELOVNEM MESTU

- Zaradi previdnosti in varnosti priporočamo, da delovno območje vzdržujete čisto in brez ovir, ki bi lahko povzročile padec.
- Prav tako poskrbite, da se otroci in hišni ljubljenci ne bodo nahajali na območju zbiranja.
- Namestitev tega izdelka zahteva uporabo lestve in delo na višini.

## 2.5 OSEBNA VARNOŠT



**POZOR: Da bi se izognili nesrečam ali poškodbam, upoštevajte teže naprave med prevozom (glejte Tehnične podatke)**

- **POZOR:** Da bi se izognili nesrečam ali poškodbam, upoštevajte teže naprave med prevozom (glejte Tehnične podatke)
- Pri ravnanju z izdelkom uporabljajte osebno zaščitno opremo. Zaščitna oprema, primerna razmeram, kot so rokavice ali zaščita za oči, zmanjša tveganje za poškodbe.
- Nosite primerna oblačila. Pri delu s tem izdelkom ne nosite ohlapnih oblačil ali nakita.
- Dolge lase zavežite nad rameni, da se ne zapletejo v gibljive dele.
- Montažo morata opraviti dve osebi. Pri steklenem nadstrešku morajo montažo opraviti 3 ali 4 osebe.
- **POZOR, NEVARNOST!** Ne plezajte na nadstrešek.
- Da bi se izognili nevarnosti poškodb zaradi vode ali električnega udara, se pred vrtnanjem prepričajte, da v steni ni skritih cevi ali kablov.
- Nekateri deli imajo kovinske robove, ki so lahko ostri. Da bi se izognili nesrečam, se oblecite ... Izdelka ne poskušajte sestaviti v vetrovnih ali vlažnih razmerah.
- Izdelka ne poskušajte sestaviti, če ste utrujeni, če ste vzeli zdravila ali v kateri koli drugi situaciji, ko nimate popolnega nadzora nad svojimi sposobnostmi.
- **OPOZORILO:** Stekla nikoli ne smete puščati na golih tleh ali položenega na ravno površino.

### 3. MONTAŽA



**OPOZORILO!** Izdelek mora biti pred uporabo v celoti sestavljen! Ne uporabljajte delno sestavljenega izdelka ali sestavljenega izdelka s poškodovanimi deli! Pri sestavljanju izdelka sledite navodilom za sestavljanje po korakih in uporabite priložene ilustracije kot vizualno vodilo za enostavno sestavljanje izdelka!



**Vedno ga postavite na rob vodoravno in na karton ali mehak material.**  
Pred začetkom dela se posvetujte z lokalnimi oblastmi, če so za namestitev izdelka potrebna dovoljenja.

#### 3.1 RAZPAKIRANJE

- Pri razpakiranju ne uporabljajte ostrih orodij (rezalnik, nož, ...), saj lahko poškodujete izdelek.

### **3.2 NAMESTITEV**

Pred začetkom dela se posvetujte z lokalnimi oblastmi, če so za namestitev izdelka potrebna dovoljenja. Sestavite posamezne sestavne dele skupaj, kot je prikazano na sliki. Če je potreben vijak, ga privijte z ustreznim orodjem.

Da bi se izognili nevarnosti poškodb in zagotovili optimalno tesnjenje, priporočamo, da tesnite s standardno silikonsko pasto.

Po sestavljanju priporočamo, da izdelek očistite z milnico in sperete s svežo vodo.

## **4. SKLADIŠČENJE**

### **4.1 SKLADIŠČENJE IZDELKA**

Ta izdelek je treba hraniti stran od vlage in naraščajoče vlage, tj. v suhem prostoru (po potrebi ogrevanem).

## **5. VZDRŽEVANJE**

### **5.1 ČIŠČENJE**

Ta izdelek bo izpostavljen številnim podnebnim vplivom: dežju, snegu, vetru, nihanju temperature ...

Za ohranitev optimalnega videza je potrebno redno vzdrževanje.

Nadstrešek očistite približno vsake tri mesece. Uporabite milo in vodo ali samo priporočena čistila iz trgovin (brez čistil ali topil) ter sperite s čisto hladno vodo.

Za čiščenje plošč ne uporabljajte acetona, abrazivnih čistil ali drugih posebnih čistilnih sredstev. S strehe odstranite sneg, umazanijo in listje.

Redno čistite žlebove (nabiranje vode lahko poškoduje nadstrešek).

Če je nadstrešek prekrit z debelo plastjo snega in ledu, ga očistite.

## **6. GARANCIJA**

### **6.1 NAŠE JAMSTVO**

Izdelki ARTENS so zasnovani v skladu z najvišjimi standardi kakovosti za izdelke, namenjene potrošniškemu trgu. Ta poprodajna garancija velja 3 let od datuma nakupa izdelka. Ta garancija zajema vse napake na delih in izdelavi: manjkajoče dele in sestavne dele ter poškodbe, ki nastanejo v normalnih pogojih uporabe. Popravila in zamenjave delov ne podaljšajo prvotnega garancijskega obdobja. Predložiti morate dokazilo o nakupu tega izdelka in datum nakupa. Garancijsko kritje je omejeno na vrednost izdelka.

### **6.2 OPUSTITVE GARANCIJE**

Ta garancija ne krije težav ali incidentov, ki so posledica nepravilne uporabe izdelka. Garancija ne velja za naslednje elemente:

- nepravilna uporaba izdelka ali
- poškodbe, ki nastanejo med prevozom ali namestitvijo tega izdelka; ali
- popravila in/ali spremembe delov, ki jih opravi tretja oseba; ali
- poškodbe, ki so posledica neupoštevanja varnostnih navodil in navodil za uporabo; ali
- izdelek je bil razstavljen ali odprt; ali
- izdelek je bil uporabljen v strokovne namene ali
- izdelek je bil izpostavljen temperaturi zunaj območja, določenega v razdelku »Skladiščenje«.

POZOR:

- Garancija je omejena na popravilo ali zamenjavo dela, ki je prepoznan kot okvarjen ali povzroča nepravilno delovanje naprave, z enakim delom (za gibljive dele in/ali potrošni material velja garancija 2 leti) ali na zamenjavo izdelka.

- Garancija v nobenem primeru ne krije potnih stroškov ter neposredne in posredne škode. Prav tako ne krije stroškov odstranitve in ponovne namestitve izdelka, za katerega se zahteva garancija, razen v okviru izvajanja zakonske garancije za skrite napake.

V primeru težav ali napak se morate vedno najprej posvetovati s prodajalcem izdelkov Artens. V večini primerov bo prodajalec izdelkov Artens lahko rešil težavo ali odpravil napako. Shranite račun ali potrdilo o prejemu: ti dokumenti bodo zahtevani pri obravnavi morebitnih pritožb.



## Introduction

Thank you for choosing this product. When designing and manufacturing our products, we make every effort to ensure excellent quality that meets the needs of users. By following these instructions, the product lifetime can be optimized.

**IMPORTANT! IN ORDER TO OBTAIN MAXIMUM SATISFACTION WITH THIS PRODUCT DURING INSTALLATION, USE AND MAINTENANCE, WE RECOMMEND YOU READ THIS USER MANUAL CAREFULLY BEFORE USING THE PRODUCT. PLEASE NOTE THE BASIC SAFETY WARNINGS IN THIS MANUAL AND KEEP THE MANUAL FOR FUTURE REFERENCE.**



**IMPORTANT, KEEP THE MANUAL FOR FUTURE REFERENCE:  
READ THIS MANUAL CAREFULLY.**

### Table of Contents

1. Intended use for this canopy
2. Safety instructions
3. Assembly
4. Storage
5. Maintenance
6. Warranty

## 1. INTENDED USE FOR THIS CANOPY

This product is generally placed above the door or even a window, it is used to protect from the sun rays and bad weather.

Once unpacking is complete, check that the product is complete and has all accessories (if applicable). If the product is damaged or defective, do not use it and return it to your retailer.

If you give this product to a third party, please also provide them with this instruction manual.

## 2. SAFETY INSTRUCTIONS

### 2.1 GENERAL SAFETY WARNINGS

- **ATTENTION :**
- To avoid any risk of tipping over, this furniture/-item must be securely fixed to the wall. Check the suitability and strength of the wall to ensure that the wall can carry the load of the furniture/object and resist the forces generated at the fixing points. Incorrect mounting can cause the furniture/object to fall and cause serious injury to people. If in doubt about the installation, ask your salesperson or contact a professional.
- Use screws, washers and dowels suitable for the type of material of your wall.
- Check that the supplied fasteners match your installation. For advice on which screws and fittings are suitable for your wall, contact a specialist retailer.

- The canopy roof is supported by brackets attached to the wall; these are not designed to carry any other load. To prevent damage to the product or injury, do not hang or place objects on the profiles.

## 2.2 SYMBOLS ON THE PRODUCT



Please read and understand all instructions before using the product, observe all warnings and safety instructions.

## 2.3 SYMBOLS IN THIS MANUAL



Type and source of danger: This symbol indicates that failure to observe this warning may result in damage to the unit, the environment or other property, biens.



Note: This symbol indicates important information for better understanding of the product.



Read the manual: This symbol indicates that you should read the user manual carefully.



This product is recyclable. If it is no longer usable, please dispose of it at a waste recycling centre.

## 2.4 WORKSPACE SAFETY

- As a precaution and for safety, we recommend that you keep your working area clean and free of obstacles that could cause falling.
- Also keep children and pets away from the assembly area.
- Fitting this product in place requires the use of a stepladder and involves working-at-heights conditions.

## 2.5 PERSONAL SAFETY



**CAUTION: To avoid accidents or injuries, keep in mind the weight of the device during transport (see Technical Data).**

- Use personal protective equipment when handling the product. Protective equipment appropriate to the conditions, such as gloves or eye protection, reduces the risk of injury.
- Wear appropriate clothing. Do not wear loose clothing or jewellery when handling this product.
- Tie long hair above shoulder level to prevent tangling with moving parts.
- Fitting should be carried out by 2 people. In the case of a glass canopy, assembly should be carried out by 3 or 4 people.
- CAUTION DANGER! Do not climb on the canopy.
- To avoid the risk of water damage or electric shock, make sure that there are no hidden pipes or cables in the wall before drilling.
- Some parts have metal edges that may be sharp. To avoid accidents, please wearDo not attempt to assemble the product in windy or humid conditions.
- Do not attempt to assemble the product if you are tired, have taken medication or in any other situation where you are not in full control of your abilities.
- WARNING! The glass should never rest on bare ground and never lie flat.

### 3. ASSEMBLY



**WARNING! The product must be fully assembled before operation! Do not use a product that is partially assembled or assembled product with damaged parts! Follow the step-by-step assembly instructions and use the illustrations provided as a visual guide to easily assemble the product!**



**Always position on the edge horizontally and on cardboard or soft material. Before starting your work, please consult local authorities in case permits are required for the installation of the product.**

#### 3.1 UNPACKING

- Do not use any sharp tools (cutter, knife,...) when unpacking, you could damage the product.



## **3.2 INSTALLATION**

Before starting your work, please consult local authorities in case permits are required for the installation of the product.

Assemble the individual components together as shown in the illustration. If a screw is required, tighten it with a suitable tool.

To avoid any risk of damage and to ensure an optimum seal, we recommend that you seal with standard silicone paste.

After assembly, we recommend cleaning the product with soapy water and rinsing with fresh water.

## **4. STORAGE**

### **4.1 PRODUCT STORAGE**

This product must be stored away from moisture and rising humidity, i.e. in a dry room (heated if necessary).

## **5. MAINTENANCE**

### **5.1 CLEANING**

This product will be subjected to many climate elements: rain, snow, wind, temperature variations ...

Regular maintenance is necessary to maintain an optimal appearance.

Clean the canopy approximately every three months. Use soap and water or only recommended cleaning products from stores (no scourers or solvents) and rinse with clear cold water.

Do not use acetone, abrasive cleaners, or other special detergents to clean the panels.

Remove snow, dirt and leaves from the roof.

Clean the gutters regularly (water accumulation could damage the canopy).

Clean the canopy if it is covered with a thick layer of snow and ice.

## **6. WARRANTY**

### **6.1 OUR GUARANTEE**

ARTENS products are designed according to the highest quality standards for products intended for the consumer market. This after-sales warranty covers a period of 3 years from the date of purchase of the product. This warranty covers all defects in parts and workmanship: missing parts and components as well as damage occurring under normal conditions of use. Repairs and changes of parts do not extend the original warranty period. You must be able to provide proof of purchase of this product and the date of purchase. Warranty coverage is limited to the value of the product.

### **6.2 DISCLAIMERS OF WARRANTY**

This warranty does not cover problems or incidents resulting from improper use of the product. The following items are not covered by the warranty:

- The product has been used improperly; or
- Damage occurring during transport or installation of this product; or
- Repairs and/or changes to parts made by a third party; or
- Damage resulting from non-compliance with the safety and operating instructions; or
- The product has been disassembled or opened; or
- The product was used for professional purposes; or
- The product has been exposed to a temperature outside the range specified in the section "Storage"

**ATTENTION :**

- The warranty is limited to the repair or replacement of the part recognized as defective or responsible for the malfunction of the device, by an identical part (moving parts and/or consumables guaranteed within the limit of 2 years) or to the exchange of the product.
- The warranty does not cover, under any circumstances, travel expenses and direct and indirect damages. It also does not cover the cost of removing and reinstalling the product covered by the warranty request, except in the context of the implementation of the legal warranty for hidden defects.

In the event of a problem or defect, you should always first consult your Artens retailer. In most cases, the Artens retailer will be able to solve the problem or correct the defect. Keep your invoice or your receipt: these documents will be requested during the processing of any complaints.



Made in CHINA



\* 3-letno jamstvo / 3-year guarantee

ADEO Services - 135 Rue  
Sadi Carnot - CS 00001 -  
59790 RONCHIN - France

[www.product-regulatory.adeoservices.com](http://www.product-regulatory.adeoservices.com)

