

**Technical requirement**

- 1' pattern draft is 1-2° of main beams ,cover ,grids, frame side.
- 2' pattern draft is 5-10° of assistive beams ,gird holes ,outside.
- 3' pattern draft is 15° of surface patterns ,mark, logo.
- 4' casting radius which aren't been marked is R1-R3.

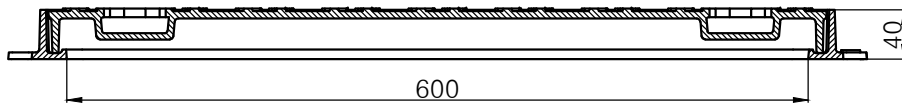

General Dimension Tolerance	General Weight Tolerance
According To ISO 8062-CT10	Tolerance(%)
	±5%

MATERIAL	GJS500-7	WEIGHT	30.2kg	CLASS	EN124-2 B125	SCALE	MARK:
						SIZE	CERTIFICATE NO. /
						695×695×40	PRODUCT CODE
						NAME	L-LGSMEN-170L
						ITEM CODE	
						EDITION	SHEET
						0	1/3

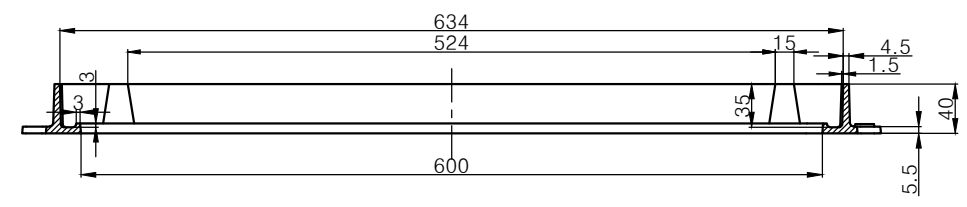
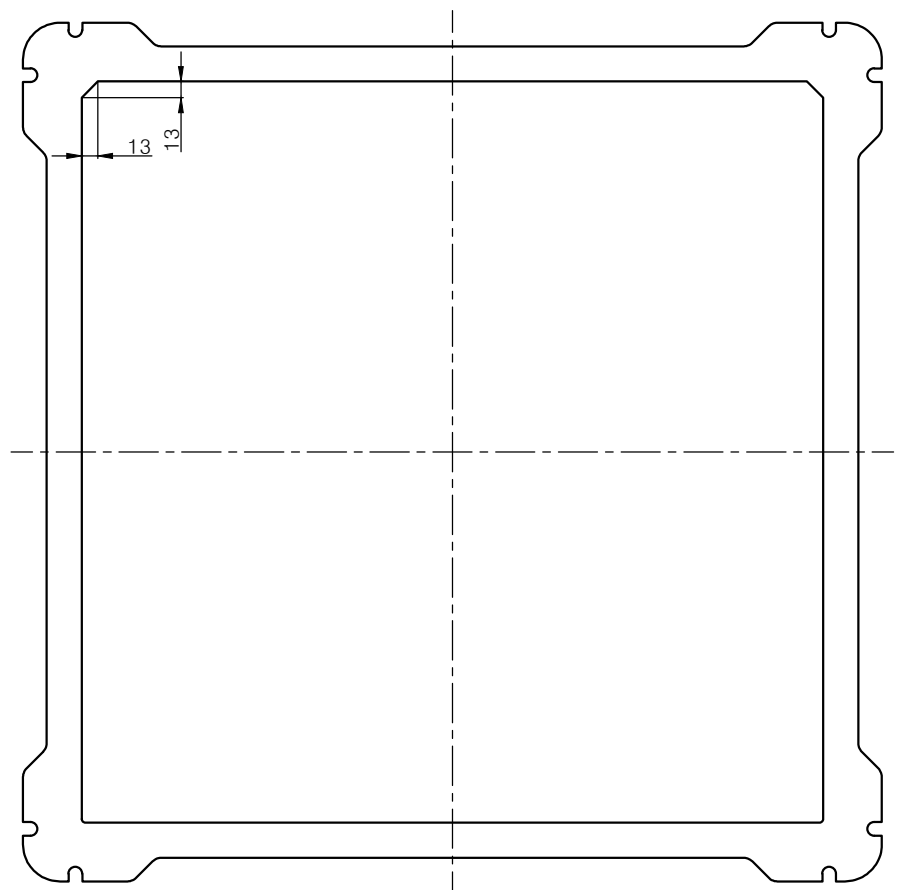
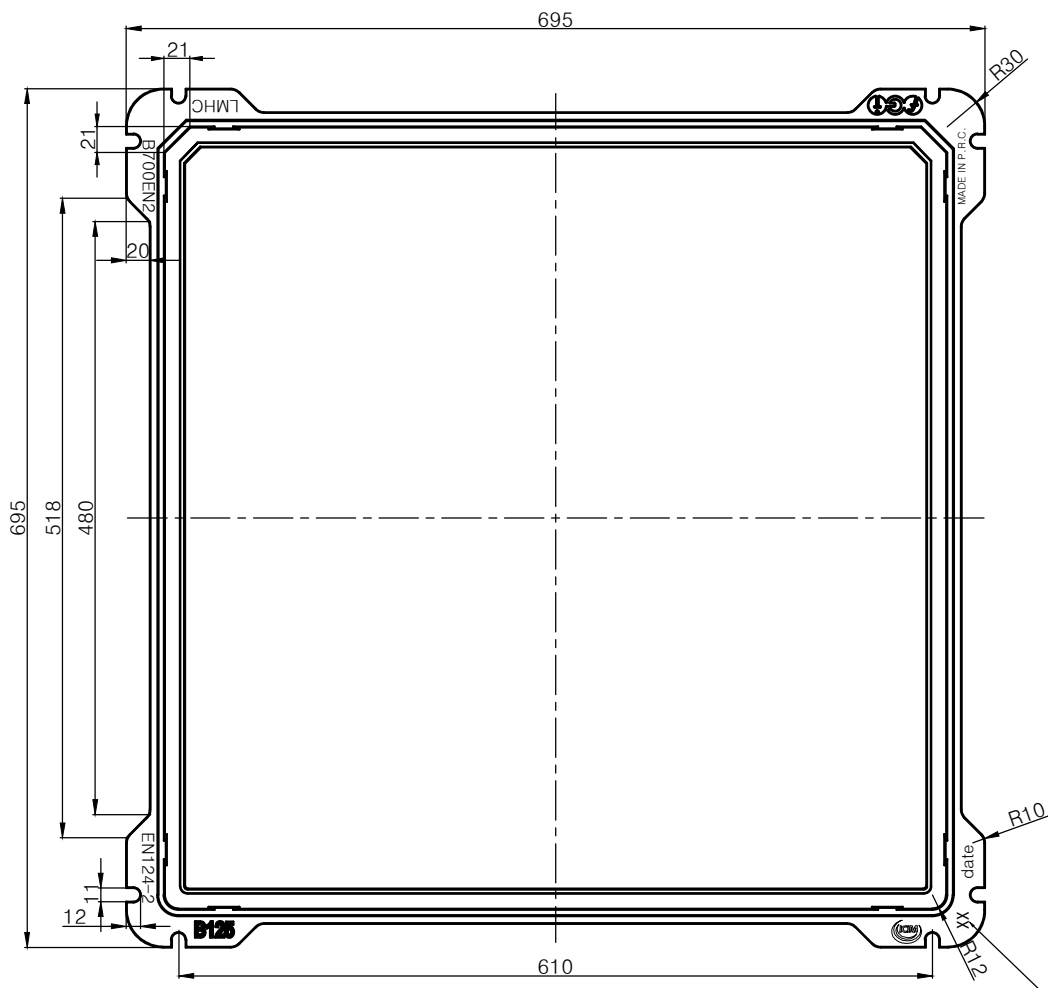

manufacturer' ID

MATERIAL	GJS500-7	WEIGHT	6.6kg	CLASS	EN124-2 B125	SCALE	MARK:		
						SIZE	CERTIFICATE NO. /		
						695x695x40	PRODUCT CODE		
						NAME	L-LGSMEN-170L		
						ITEM CODE			
									
						OBLIKUJEMO VODNI CESTI			
							EDITION	0	SHEET
									2/3

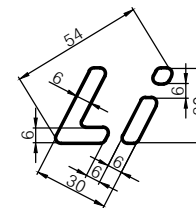
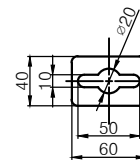
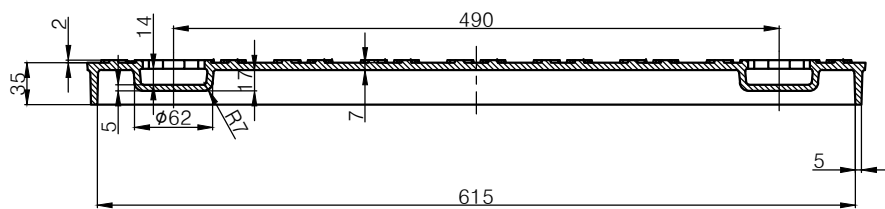
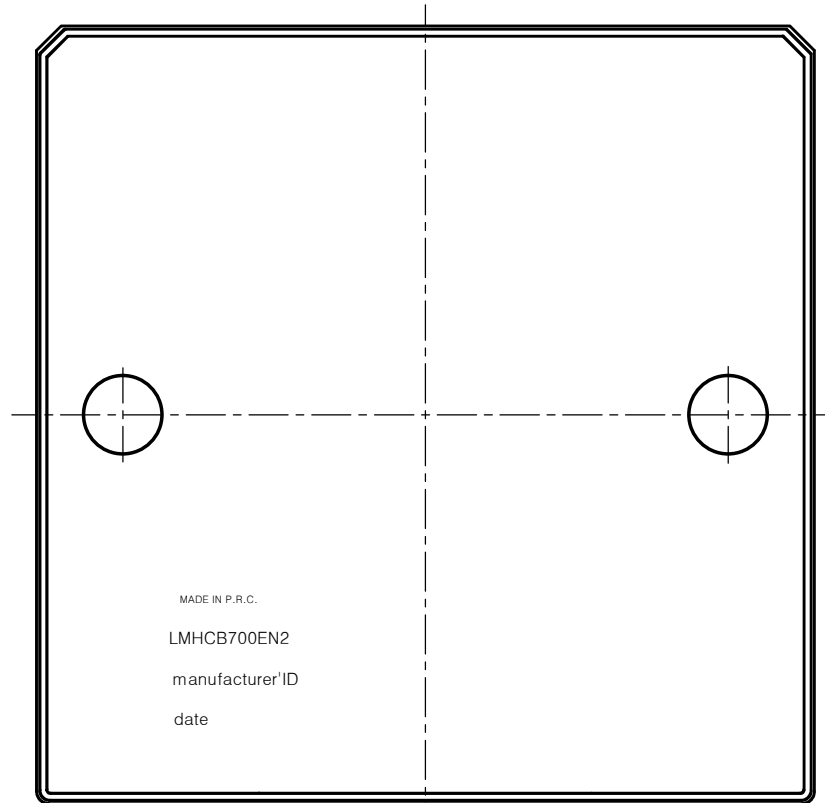
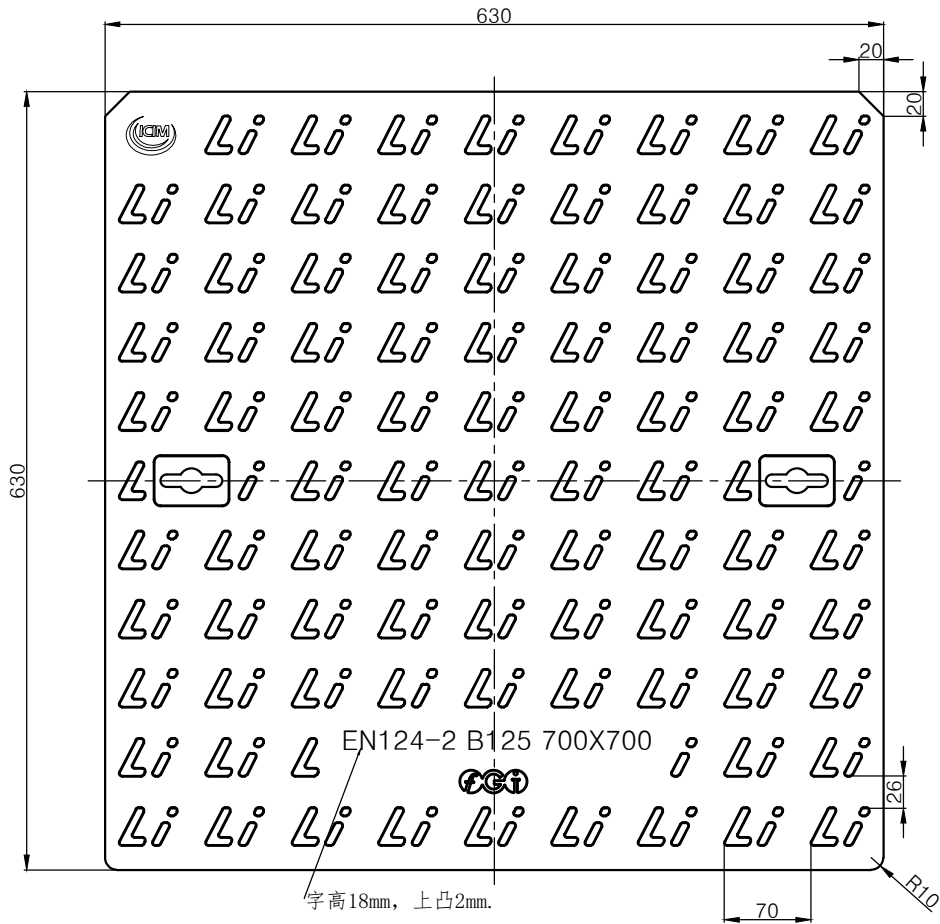

MATERIAL	GJS500-7	WEIGHT	23.6kg	CLASS	EN124-2 B125	SCALE	MARK:	
						SIZE	CERTIFICATE NO. / PRODUCT CODE	
						695x695x40		
						NAME	L-LGSMEN-170L	
						ITEM CODE		
						EDITION	0	SHEET
								3/3